

High Pressure Pump Series HDP 480

Design criteria

Hammelmann high pressure pumps are built to operate at the continuous maximum duty stated in the performance parameters. Just compare the crankshaft speed, average plunger speed, plunger diameter and power rating.

High pressure pump

Weight: 4.320 lbs

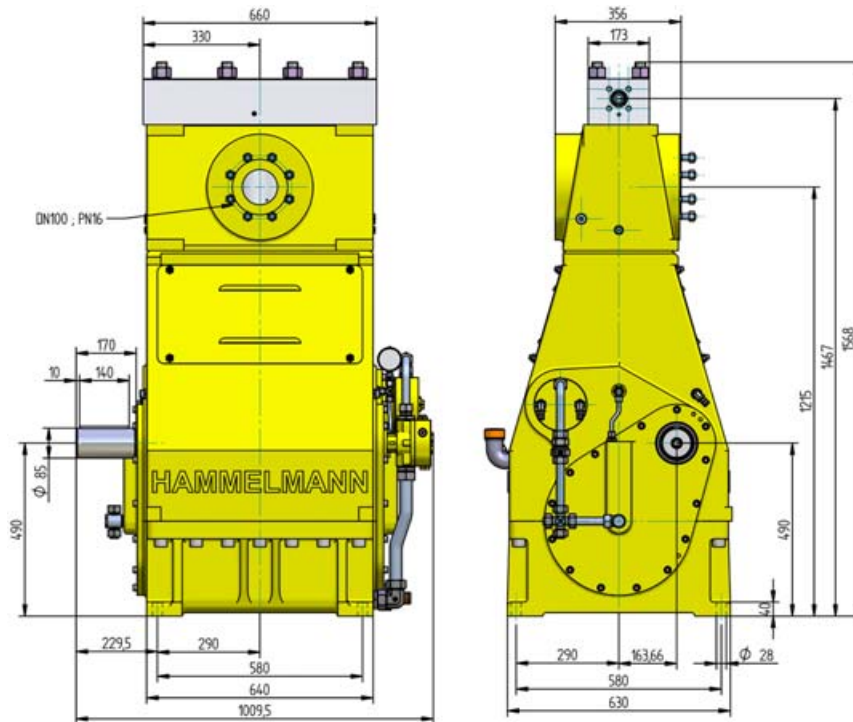

Features

- Power ratings up to 640 HP
- Vertical 3 cylinder design
- Wide variety of complementary ancillaries

Quality and reliability

- Stainless steel stress free pump head
- Cross head piston bellows seal
- Choice of 'application specific' seal assemblies
- Solid ceramic or tungsten carbide plungers
- Choice of bronze or stainless steel suction chamber
- Crank section calculation by 'Finite element method' ensures long working life under continuous load
- Crankshaft supported by 2 bearings and incorporating twin helical speed reducing gears
- Pressurised oil lubrication system with oil cooler/filter

Stationary unit with electric motor

Length: 114 inch
Width: 52 inch
Height: 75 inch
Weight: approx. 12,348 lbs at 536 HP

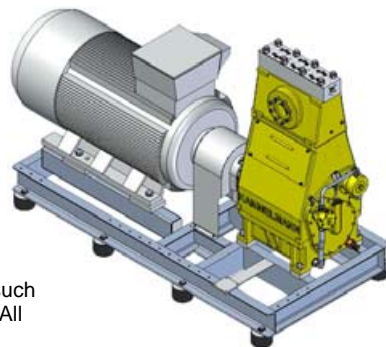

Main dimensions without accessories such as suction line, pressure regulator etc. All shown as right side drive. Detailed dimensional drawings and weights available on request.

Stationary unit with diesel engine

Length: 120 inch
Width: 66 inch
Height: 94 inch
Weight: approx. 14,773 lbs at 700 HP with full fuel tank

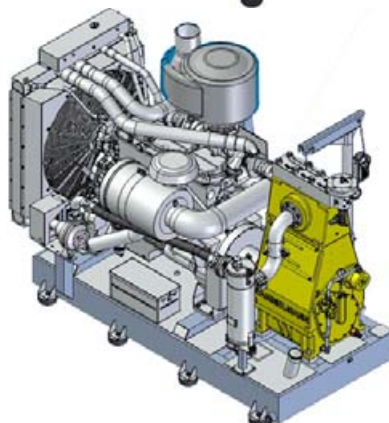

HAMMELMANN[®]

HDP 480 series, technical data

Calculated performance parameters

Q [GPM]	Required power rating [HP]				D	r.p.m.	
	400	470	540	600		n 1	n 2
Operating pressure [psig]							
14.0	43500				28	1500	315
16.6	37000	42800	43500			1500/1800	380
20.3	30500	35500	39900	43500		1800	465
21.9	26800	29700			35	1500	315
26.4	22500	26100	29700			1500/1800	380
32.2	18100	21000	24700	27600		1800	465
29.0	20300	23200			40	1500	315
34.8	16700	19600	22500	23200		1500/1800	380
42.2	14200	16700	18900	21000		1800	465
37.0	16000	18100			45	1500	315
44.4	13500	15700	17400	18100		1500/1800	380
54.1	11200	13100	14900	16700		1800	465
46.2	13300	14800			50	1500	315
55.4	11000	12800	14500	14800		1500/1800	380
67.6	9100	10600	12000	13600		1800	465
56.5	11000	12200			55	1500	315
67.8	9000	10400	12000	12200		1500/1800	380
82.6	7500	8700	10000	11200		1800	465
68.1	9300	10300			60	1500	315
81.6	7500	8800	10000	10300		1500/1800	380
99.5	6400	7300	8400	9400		1800	465
80.8	7800	8700			65	1500	315
96.9	6500	7500	8600	8700		1500/1800	380
118.0	5400	6200	7100	8000		1800	465
93.5	6800	7500			70	1500	315
112.2	5500	6400	7400	7500		1500/1800	380
136.8	4600	5400	6100	7000		1800	465
122.2	5200	5800			80	1500	315
146.8	4200	4900	5700	5800		1500/1800	380
178.7	3500	4100	4600	5200		1800	465
154.7	4100	4500			90	1500	315
185.6	3300	3900	4500			1500/1800	380
226.2	2800	3200	3600	4200		1800	465
190.9	3300	3600			100	1500	315
229.2	2800	3200	3600			1500/1800	380
279.3	2200	2600	2900	3300		1800	465

- Rod force: 147,500 lbf
- Stroke: 3.94 inch
- Mean piston speed at n₂
- 315 r.p.m. = 3.5 feet/sec
- 380 r.p.m. = 4.2 feet/sec
- 465 r.p.m. = 5.1 feet/sec

Typical high pressure pump units



- Stationary unit with diesel motor



- Diesel unit installed in vehicle



- Stationary unit with electric motor

D = Piston/Plunger dia. [mm]
n1 = Motor/Engine r.p.m. [1/min]
n2 = Crankshaft r.p.m. [1/min]

Type designations

Sealing system	D	HDP Type
Hydrodynamic with tungsten carbide plungers	1.1 – 1.38	484
Hydrodynamic with solid ceramic plungers	1.57	483
Labyrinth with solid ceramic plungers	1.77 – 2.76	482
Packed sleeves with solid ceramic plungers	1.77 – 3.94	487

D = Plunger dia. [inch]

Hammelmann Corp. 600 Progress Road
Dayton, Ohio 45449
eMail: mail@hammelmann.com

Phone: (001) 937-859-8777
Fax: (001) 937-859-9188
http:// www.hammelmann.com

